

**Aviation Fabricators Inc.
805 North Fourth Street
Clinton, MO. 64735**

INSTRUCTIONS FOR CONTINUED AIRWORTHINESS

For

Headrest Assembly

Document No.: AF-471

Revision "C"

Revision Date: 11/18/13

Applicable to:

Hawker Beechcraft models C90, C90A, E90, F90, A100, B100,
200, 200T, 200C, 200CT, B200, & 300

Modified by FAA STC SA01576WI

The information in the Instruction for Continued Airworthiness is FAA accepted material and complies with 14 CFR 23.1529, Instructions for Continued Airworthiness. It supersedes or adds to that provided in the Maintenance Manual for the Hawker Beechcraft C90, C90A, E90, F90, A100, B100, 200, 200T, 200C, 200CT, B200, & 300 Aircraft, only where covered in the items contained herein. For limitations and procedures not contained in the Supplement, consult the Component Maintenance Manual, or other approved airplane data.

REVISION PAGE

Document Title: Instructions for Continued Airworthiness

Prepared By: Todd Pogue

Log of Revisions				
REV. NO.	EFFECTED PAGE(S)	DESCRIPTION	DATE	APPROVED BY
A	All	*Updated the entire document with relevant format	07/29/09	GRL
B	All	*Updated Section 10 to latest format *Added Section 11 Troubleshooting	07/11/13	JRL
C	All	*Added new headrest p/n 32-0407 to the document	11/18/13	JRL

Per the requirement of Appendix G of 14 CFR Part 23 paragraph G23.1 (c), the changes made to the ICA by the applicant will be distributed via mail by means of paper copy.

TABLE OF CONTENTS

DESCRIPTION	PAGE
INSTRUCTIONS FOR CONTINUED AIRWORTHINESS	1
REVISION PAGE	2
TABLE OF CONTENTS	3
ABBREVIATIONS AND DEFINITIONS.....	4
1.0 INTRODUCTION.....	5
2.0 INSPECTION REQUIREMENTS AND OVERHAUL SCHEDULE.....	7
3.0 DIMENSION AND ACCESS:	8
4.0 LIFTING AND SHORING	8
5.0 LEVELING AND WEIGHING	8
6.0 TOWING AND TAXIING	8
7.0 PARKING AND MOORING.....	8
8.0 PLACARDS AND MARKINGS.....	8
9.0 SERVICE INFORMATION	9
10.0 AIRWORTHINESS LIMITATIONS	10
11.0 TROUBLESHOOTING.....	10

ABBREVIATIONS AND DEFINITIONS

Abbreviations	Definitions
AML	FAA Approved Model List (AML)
Detailed Inspection (DET)	An intensive examination of a specific item, installation or assembly to detect damage, failure or irregularity. Available lighting is normally supplemented with a direct source of good lighting at an intensity deemed appropriate. Inspection aids such as mirrors, magnifying lenses, etc. may be necessary. Surface cleaning and elaborate access procedures may be required.
FAA	Federal Aviation Administration
FAA MIDO	FAA Manufacturing Inspection District Office
General Visual Inspection (GVI)	A visual examination of an interior or exterior area, installation or assembly to detect obvious damage, failure or irregularity. This level of inspection is made from within touching distance unless otherwise specified. A mirror may be necessary to enhance visual access to all exposed surfaces in the inspection area. This level of inspection is made under normally available lighting conditions such as daylight, hanger lighting, flashlight or droplight and may require removal or opening of access panels or doors. Stands, ladders or platforms may be required to gain proximity to the area being checked.
ICA	Instructions for Continued Airworthiness
Special Detailed Inspection (SDI)	An intensive examination of a specific item, installation , or assembly to detect damage, failure or irregularity. The examination is likely to make extensive use of specialized Inspection Techniques and/or equipment. Intricate cleaning and substantial access or disassembly procedure may be required.
STC	Supplemental Type Certificate

1.0 INTRODUCTION

The purpose of this Maintenance Manual Supplement and Instructions for Continued Airworthiness (ICA) is to provide the maintenance technician with the information necessary to ensure the continued airworthiness of the Aviation Fabricators headrest assemblies, per installation numbers 32-0349K and 32-0407K, when installed onto existing OEM seats in the aircraft passenger cabin in accordance with Aviation Fabricators design data included on Drawing List AF-273 and per Supplement Type Certificate (STC) No. SA01576WI.

Modifications to an aircraft obligates the operator to include the maintenance information provided by this document into the operators aircraft Maintenance Manual and operator's aircraft scheduled maintenance program. This document defines supplementary maintenance operations and frequencies recommended by Aviation Fabricators Inc., to ensure the aircraft's airworthiness.

The information contained herein addresses the requirements specified in 14 CFR 23.1529, Instructions for Continued Airworthiness and supplements the basic Airplane Maintenance Manual only in those areas listed as pertains to the installation of headrest assemblies, as installed per the Aviation Fabricators Drawing List AF-273. For limitations and procedures not contained in this supplement, consult the basic Airplane Maintenance Manual.

DATA

All information to support the continued airworthiness of this modification is contained in:

STC SA01576WI.
STC Drawing List: AF-273.

Installation: Installation Instructions D-10532, p/n's 32-0349K and 32-0407K

Parts: p/n 32-0349, Headrest Assembly
p/n 32-0407, Headrest Assembly

The new headrest is a replacement headrest to be used on existing OEM seats. It is installed in the same manner as the existing headrest assemblies by inserting the headrest frame into the seat back supports.

Design Change Control

All data and changes to the parts and assemblies will be tracked per STC Drawing List AF-273 Rev D or later approved revision.

Applicable Aircraft

Hawker Beechcraft models C90, C90A, E90, F90, A100, B100, 200, 200T, 200C, 200CT, B200, & 300

Headrest Assembly
P/N 32-0349K

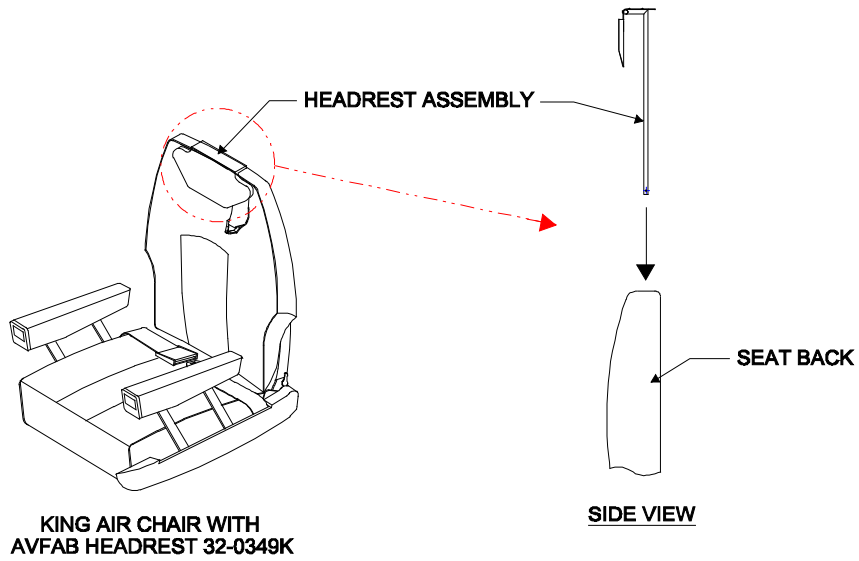

Figure 1.0A

Headrest Assembly
P/N 32-0407K

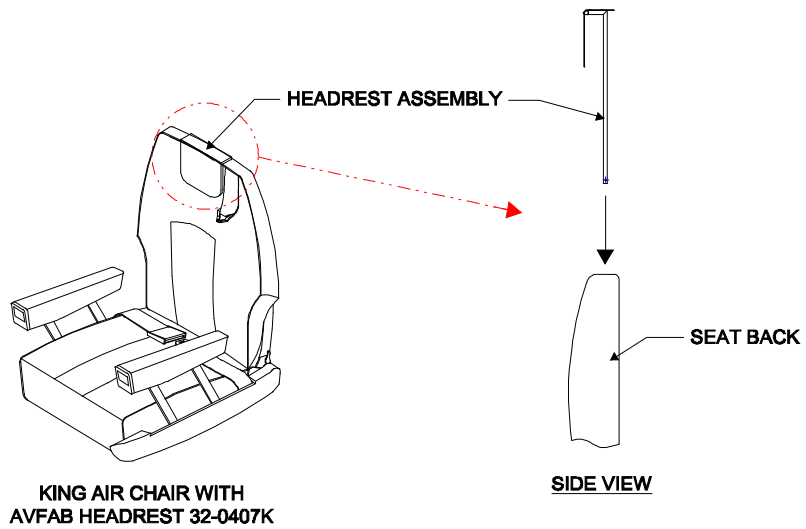

Figure 1.0B

2.0 INSPECTION REQUIREMENTS AND OVERHAUL SCHEDULE

1. To comply with 14 CFR 23.1529, continue the new headrest assembly on the same inspection and maintenance schedule used per the Hawker Beechcraft Maintenance Manual for seats and divans.
 - a. The new headrest assembly requires no service other than inspection at normal Phase 4 inspection schedule of 800 hours or 24 months whichever occurs first.

Task Code			Schedule	Date	Mech	Insp
AFI-100	a.	Inspect for damage to upholstery.				
AFI-101	b.	Inspect frame for damage, and corrosion.				

3.0 DIMENSION AND ACCESS:

The installation of the new headrest assembly does not change the dimensions of the aircraft or alter the access to any existing aircraft system.

4.0 LIFTING AND SHORING

No change.

5.0 LEVELING AND WEIGHING

No change.

6.0 TOWING AND TAXIING

No change.

7.0 PARKING AND MOORING

No change.

8.0 PLACARDS AND MARKINGS

(1) placard is required in conjunction with this modification:

1. Aft facing seat with the new headrest assembly installed must have placard part number 15-0482 located so that is in plain view of the seat occupant.

**HEADREST MUST BE IN RAISED
POSITION DURING TAKE OFF &
LANDING FOR AFT FACING SEATS**

Figure 8.0A

9.0 SERVICE INFORMATION

Typical Service Instructions:

A. Upholstery Cleaning:

Headrest Service Instructions

1. If possible dry clean fabric covering.
2. If dry cleaning is not possible clean fabric with Armour All fabric cleaner or equivalent.
3. Clean leather with Armour All leather cleaner or equivalent.
4. Clean and inspect overall headrest assembly for fit and function.

Typical Maintenance Instructions:

Headrest Assembly

The headrest assembly is removed from the OEM seat by pulling upward on the headrest until the frame clears the seat back supports.

The headrest assembly is installed onto the OEM seat by inserting the headrest frame with the spring pins into the seat back supports and pushing down.

B. RECOMMENDED OVERHAUL PERIODS

No additional overhaul time limitations and requirements apply to the Aviation Fabricators' headrest assembly.

10.0 AIRWORTHINESS LIMITATIONS

The Airworthiness Limitations section is FAA approved and specifies maintenance required under Sec. 43.16 and 91.403 of the Federal Aviation Regulations unless an alternative program has been FAA approved.

There are no Airworthiness Limitations to the aircraft with the addition of the headrest assembly installed by this STC.

11.0 TROUBLESHOOTING

Refer to the existing Aircraft Maintenance Manual for troubleshooting the divan installation that is required beyond the information found on the installation drawings per STC Drawing List AF-273.

For replacement parts or repair of damage parts:

Contact Aviation Fabricators at (660) 885-8317.

Troubleshooting this installation should only be accomplished by FAA approved repair stations with the appropriate ratings or appropriately rated operator/individuals, with required test equipment and service data.